

# Indigo™ Series 450 Ice Cube Machine

Model:  ID-0452A  IY-0454A  ID-0453W  IY-0455W



Indigo Series i-450  
Ice Machine on B-400 Bin

Designed for operators who know that ice is critical to their business, the Indigo™ Series ice machine's preventative diagnostics continually monitor itself for reliable ice production. Improvements in cleanability and programmability make your ice machine easy to own and less expensive to operate.

- **Space-Saving Design** – Up to 450 lbs. (204 kgs.) daily ice production and only 30" (76.20 cm) wide.
- **Intelligent Diagnostics** – provide 24 hour preventative maintenance and diagnostic feedback for trouble free operation.
- **Acoustical Ice Sensing Probe** – for reliable operation in challenging water conditions.
- **EasyRead Display** – communicates operating status, cleaning reminders, and asset information through a blue illuminated display.
- **Programmable Ice Production** – by On/Off Time, Ice Volume or Bin Level (with accessory bin level control) further improves energy efficiency and savings.
- **Easy to Clean Foodzone** – Hinged front door swings out for easy access. Removable water-trough, distribution tube, curtain, and sensing probes for fast and efficient cleaning. Select components made with AlphaSan® antimicrobial.
- **DuraTech™ Exterior** – provides superior corrosion resistance. Stainless finish with innovative clear-coat resists fingerprints and dirt.
- Available **LuminIce™ Growth Inhibitor** controls the growth of bacteria and yeast within the foodzone.

## Ice Machine Electric

115/60/1 standard.  
(208-230/60/1 and 230/50/1 also available)

### Minimum circuit ampacity:

Air-cooled: 13.2  
Water-cooled: 12.5

### Maximum fuse size:

20 amps 1ph

## Specifications

### BTU Per Hour:

5,400 (average) 6,300 (peak)

### Refrigerant:

R-404A CFC-free

### Operating Limits:

- Ambient Temperature Range: 35° to 110°F (1.7° to 43.3°C)  
Water Temperature Range: 35° to 90°F (1.7° to 32.2°C)
- Water Pressure Ice Maker  
Water In:  
Min. 20 psi (137.9 kPa)  
Max. 80 psi (551.1 kPa)



## Ice Shape



**Half Dice**  
3/8" x 1 1/8" x 7/8"  
(.95 x 2.86 x 2.22 cm)



**Dice**  
7/8" x 7/8" x 7/8"  
(2.22 x 2.22 x 2.22 cm)





# Indigo™ Series 450 Ice Cube Machine

## i-450 on B-400 Storage Bin

**Installation Note**  
Minimum installation clearance:  
Top/sides: 8" (20.32 cm);  
Back is 5" (12.7 cm)

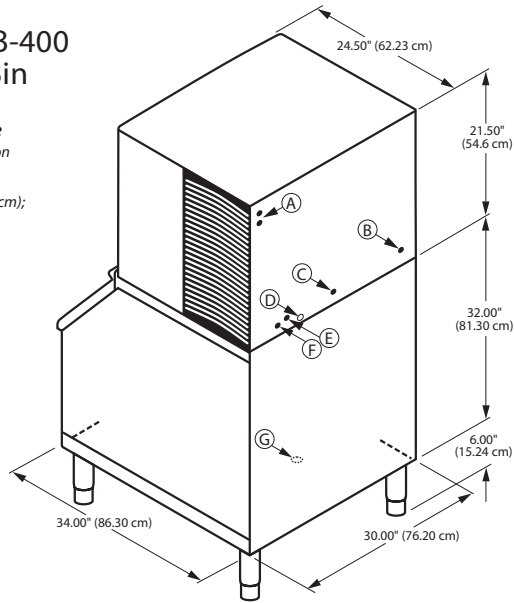

- (A) Electrical Entrance (2) Options
- (B) 3/8" (0.95 cm) F.P.T. Water Condenser Inlet (water-cooled units)
- (C) 1/2" (1.27 cm) F.P.T. Water Condenser Outlet (water-cooled units)
- (D) 1/2" (1.27 cm) Auxillary Base Drain Socket
- (E) 3/8" (0.95 cm) F.P.T. Ice Making Water Inlet
- (F) 1/2" (1.27 cm) F.P.T. Ice Making Water Drain
- (G) 3/4" (1.91 cm) Bin Drain

## Space-Saving Designs



	<b>i-450 B-400</b>	<b>i-450 B-570</b>
Height	59.50" 151.13 cm	71.50" 181.61 cm
Width	30.00" 76.20 cm	30.00" 76.20 cm
Depth	34.00" 86.30 cm	34.00" 86.30 cm
Bin Storage	290 lbs. 131.7 kgs.	430 lbs. 195.2 kgs.

Height includes adjustable bin legs 6.00" to 8.00", (15.24 to 20.32 cm) set at 6.00" (15.24 cm).

## Specifications

	Model	Ice Shape	Ice Production 24 Hours		Power Usage kWh/100 lbs. @90°Air/70°F	Water Usage/ 100 lbs. 45.4 kgs. of Ice	ENERGY STAR*
			70°Air/ 50°F Water	90°Air/ 70°F Water			
<b>AIR-COOLED</b>	ID-0452A	dice	420 lbs.	320 lbs.	6.24	24.4 Gal.	★
			191 kgs.	145 kgs.		92.4 L	
<b>AIR-COOLED</b>	IY-0454A	half-dice	450 lbs.	335 lbs.	5.97	24.4 Gal.	★
			204 kgs.	152 kgs.		92.4 L	
<b>WATER-COOLED</b>	ID-0453W	dice	430 lbs.	360 lbs.	4.70	24.4 Gal.	NA
			195 kgs.	163 kgs.		92.4 L	
	IY-0455W	half-dice	450 lbs.	360 lbs.	4.70	24.4 Gal.	NA
			204 kgs.	163 kgs.		92.4 L	

\* Water-cooled Condenser Water Usage / 100 lbs. /45.4 kgs. Of Ice: 169 gal/640 L.  
\* Water-cooled models are excluded from ENERGY STAR qualification.

Order ice storage bin separately.

## Accessories

**LuminIce™ Growth Inhibitor**  
reduces yeast and bacteria growth for a cleaner ice machine.



**Bin Level Control**  
Allows ice bin level to be automatically set. Built-in LED light illuminates bin.



**Arctic Pure® Water Filters**  
Reduces sediment and chlorine odors for better tasting ice.



**AuCS®**  
schedules and performs routine ice machine cleaning automatically.

