

## RANGE COMPOSITION

A range which combines experience and innovation; is new in performance, excellent in quality and economical in use. The ideal solution for smaller catering outlets requiring appliances with compact dimensions, low installed electric power, flexible use, reduced energy and condiments consumption, up-to-date design and maximum reliability.

The range consists of 1 four grid electric model ideal for all traditional oven cooking - sweets, meat, fish, vegetables, grilling, "au-gratin" cooking and the regeneration of chilled and frozen foods. This oven can be positioned on tables thanks to the height-adjustable feet that are supplied as standard.



FCFE4

# FCF-4

## FORCED AIR CONVECTION OVEN **ZANUSSI** PROFESSIONAL

### FUNCTIONAL AND CONSTRUCTION FEATURES

- ◆ Cooking is uniform throughout the oven and different foods can be cooked simultaneously without transference of aromas or flavour.
- ◆ External panelling, door, door handle, sides, front panel and top in stainless steel AISI 304. The door has a double glass and a silicone seal resistant to temperature and ageing. The FCF/4 has a drop down door.
- ◆ The oven has a full set of commands and controls to guarantee maximum automation of the cooking process.
- ◆ The control panel features a main control knob which switches the oven on, operates the lighting in the oven chamber, has a fan position for the defrosting of frozen foods at ambient temperature, sets the oven temperature from 50° to 230°C and has a grill position for "au gratin" cooking.
- ◆ Timer for adjusting cooking times from 0 to 120 minutes; at the end of the set time the heating elements and fan are automatically cut off and an audible warning given.

- ◆ Indicator lights to show the appliance is on and thermostat.
- ◆ The oven chamber, in enamelled steel ("easy to clean"), has been designed with rounded corners to facilitate cleaning. The grid supports are removable without the use of tools.
- ◆ Heating via armoured elements positioned on the ceiling of the oven chamber (grill) and on the convection group.
- ◆ Equipped with fat filter, 1 450x370 mm chrome grid, 1 h. 20 enamelled pan and 1 h. 35 enamelled pan.
- ◆ All models comply with the standards required by the main international approval bodies and are H marked.

TECHNICAL DATA	
CHARACTERISTICS	MODELS
	FCFE4 240271
Functional level	Base, Manual
Power supply	Electric
Type of grids	450x370 mm
Shelf capacity	4
Cooking cycles - °C	
air-convection	230
Convection	●
External dimensions - mm	
width	600
depth	595
height	635
Internal dimensions - mm	
width	465
depth	390
height	352
Power - kW	
cooking chamber	2,5
electric	2,5
Supply voltage	230 V, 1+N
Frequency - Hz	50
Net weight - kg.	40,5
INCLUDED ACCESSORIES	
450X370 MM GRID FOR OVENS	1
H20 ENAMELLED PAN FOR 4 GRID OVENS	1
H35 ENAMELLED PAN FOR 4 GRID OVENS	1

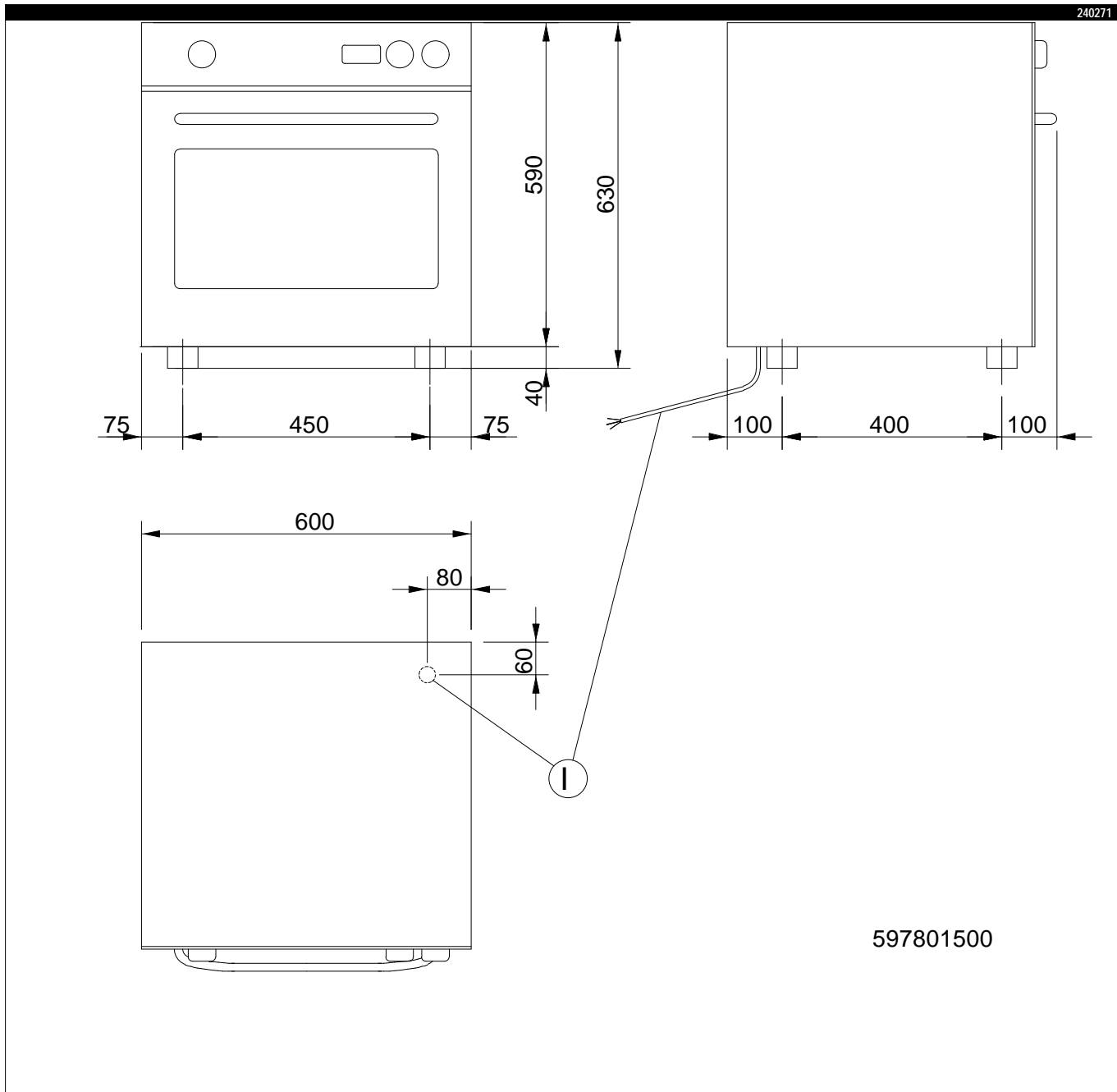

LEGEND	
I - Electrical connection	FCFE4 240271 230 V, T+N



OPTIONAL ACCESSORIES	
ACCESSORIES	MODELS
	FCFE4 240271
450X370 MM GRID FOR OVENS	921050
H20 ENAMELLED PAN FOR 4 GRID OVENS	921051
H35 ENAMELLED PAN FOR 4 GRID OVENS	921052



www.zanussiprofessional.com